

Real-time B-mode ultrasound quality control test procedures^{a)}

Report of AAPM Ultrasound Task Group No. 1

Mitchell M. Goodsitt^{b)} and Paul L. Carson
Department of Radiology, University of Michigan, Ann Arbor, Michigan 48109-0030

Scott Witt^{c)}
Gammex RMI, Middleton, Wisconsin 53562-0327

David L. Hykes
Department of Radiation Therapy, St. Joseph Hospital and Health Center, Lorain, Ohio 44052

James M. Kofler, Jr.
Department of Radiology, Mayo Clinic, Rochester, Minnesota 55904

(Received 30 March 1998; accepted for publication 3 June 1998)

[S0094-2405(98)02608-X]

TABLE OF CONTENTS

I. INTRODUCTION: WHY ULTRASOUND QUALITY CONTROL?.....	1385	3. Lateral resolution or response width.....	1397
II. TEST SCHEDULE.....	1386	4. Ring down or dead zone.....	1398
III. PERFORMING THE BASELINE TESTS.....	1386	5. Slice thickness or elevational focus.....	1399
A. Selecting instrument control settings.....	1386	C. Film sensitometry.....	1400
B. Determining baseline values.....	1386	1. Establishing operating levels.....	1401
C. Selecting the action levels.....	1387	2. Control films and film emulsion crossover..	1401
IV. SUGGESTED VALUES FOR IMAGE QUALITY INDICATORS.....	1387	3. Example of performing a crossover.....	1401
V. TEST OBJECT (PHANTOM) DESIGN REQUIREMENTS.....	1387	4. Processing sensitometry strips.....	1402
VI. COMPUTERIZED IMAGE ANALYSIS.....	1389	ACKNOWLEDGMENTS.....	1402
VII. QUALITY CONTROL TESTS.....	1389	APPENDIX A: ABBREVIATED PERFORMANCE TEST INSTRUCTIONS.....	1402
A. Frequently performed quality control tests.....	1389	APPENDIX B: QUALITY CONTROL TEST FORMS.....	1404
1. Physical and mechanical inspection.....	1389	1. Physical and mechanical inspection.....	1404
2. Display monitor setup and fidelity.....	1390	2. Hardcopy and display monitor fidelity.....	1404
3. Image uniformity.....	1391	3. Image uniformity.....	1404
4. Depth of penetration/visualization.....	1392	4. Depth of visualization.....	1404
5. Photography (hard copy) fidelity.....	1393	5. Vertical and horizontal distance accuracy.....	1404
6. Distance accuracy.....	1394	6. Anechoic object perception.....	1405
B. Less frequent quality control tests.....	1394	7. Axial resolution.....	1405
1. Anechoic object imaging.....	1394	8. Lateral resolution.....	1405
2. Axial resolution.....	1396	9. Ring down or dead zone.....	1405
		APPENDIX C: EXAMPLES OF PHANTOM DESIGNS.....	1405
		REFERENCES.....	1406

I. INTRODUCTION: WHY ULTRASOUND QUALITY CONTROL?

It is sometimes argued that there is no need for ultrasound (US) quality control (QC) testing because (1) the new machines are very reliable and rarely break down, and (2) the sonographer will detect image quality defects during normal scanning. Although both of these statements may be true, they do not necessarily negate the utility of US QC tests. A primary reason is that a set of periodic definitive measurements for each transducer and US unit can identify degradation in image quality before it affects patient scans. Another is that when equipment malfunction is suspected, QC tests can be employed to determine the source of the malfunction.

Even equipment that is under warranty or service contract should be checked periodically. QC tests can verify that equipment is operating correctly and repairs are done properly.

A quality assurance (QA) program involves many activities including: quality control testing, preventive maintenance, equipment calibration, in-service education of sonographers, bid specification writing and bid response evaluation, acceptance testing of new equipment, and evaluation of new products.¹ The purpose of the present document is to describe routine ultrasound QC tests to be performed by or under the supervision of a medical physicist. Descriptions of other QA activities, in particular acceptance testing of US equipment, are beyond the scope of this document. Further

information on ultrasound QC tests can be found in other documents.²⁻⁵

The following is a detailed set of instructions for setting up and performing ultrasound QC tests. An abbreviated instruction set is also included in Appendix A for the operator's convenience. Examples of individual QC test forms are included in Appendix B, and examples of possible phantom designs are provided in Appendix C.

II. TEST SCHEDULE

There is a strong commitment to performing at least once a year comprehensive tests of x-ray imaging equipment such as mammographic and fluoroscopic units. Depending upon the complexity of the x-ray equipment, and the number and nature of the tests, the entire set of tests is completed in about 1–8 h. There are no factors in an US unit which would indicate the need for more frequent thorough QC evaluations than is needed for general radiography, so long as servicing is competent and the US technologists are well trained and attentive. However, in the interest of discovering problems before they become serious, it is recommended that certain tests of short duration be performed more frequently. These are termed the "quick scan" tests. They include display monitor fidelity, image uniformity, depth of visualization, hard copy fidelity, vertical distance accuracy, and horizontal distance accuracy. Only the most frequently employed transducer is evaluated in these tests. The quick scan tests plus a physical and mechanical inspection should be performed every three months for mobile and emergency room systems and every six months for others. The total time commitment for the quick scan tests plus the physical and mechanical inspection should be about 15 min per US unit. The more thorough set of tests, analogous to those for x-ray equipment, should be performed annually. Normally, it should take about 1–2 h to perform the more thorough set of tests on a single ultrasound unit with its associated transducers.

The final record of an ultrasound exam is often in the form of images stored on transparent film. When this is true, it is imperative that film processor QC tests be performed. Most of these processor tests are carried out on a daily basis. They are described in the ACR Mammographic Quality Control Manual.⁶ To make the present US manual independent and complete, descriptions of these tests are also included here.

For the efficient implementation of a QA program, the authors advocate developing a QC test calendar which indicates the dates on which each unit and transducer are to be tested. This calendar should include an area to check off when the tests are completed.

III. PERFORMING THE BASELINE TESTS

The baseline represents the instrument's peak performance for a particular image quality indicator. Subtle changes in image quality can be detected by comparing the current value with the baseline value.

The baseline tests establish the instrument control settings to be used for the periodic image quality tests and determine

the baseline values for each image quality indicator. For the best representation of an instrument's peak performance, the baseline tests should be performed immediately after the instrument has been installed and accepted. To ensure that existing systems are operating up to specification, it is best to perform the baseline tests immediately after preventive maintenance and service by a qualified engineer. If this is not possible, and a particular system is between service calls at the time of the baseline tests, one should immediately after the next service call measure each image quality indicator and adjust the original baseline values if the measurements improve (if the indicator values degrade, the system should be repaired). Remember, the baseline values are the landmarks for detecting changes in image quality.

A. Selecting instrument control settings

A good tissue mimicking phantom allows the use of normal control settings during QC tests. To select the control settings for the image quality tests, scan the phantom as if it were a patient and adjust the controls to produce the best possible clinical image, taking care not to emphasize or exaggerate a particular image attribute. Be sure to adjust and record the video monitor's brightness and contrast settings under "clinical" room lighting conditions. These same dim lighting conditions should be employed while performing all QC imaging tests. When the setup is deemed acceptable, record each of the control settings on the data sheet for the scanner-transducer pair in use. Examples of the settings that should be recorded include dynamic range, gray level map, body part menu selection, power level, gain level, and time gain compensation (TGC). Some of the image quality tests will require different settings for image and focal zone depth. Suggested initial settings for these tests are provided in the instructions, but the settings may need to be altered. Be sure to record the final settings on the data sheet and use them every time the tests are performed. It cannot be emphasized enough that the parameters that are being measured are highly dependent upon the machine and display monitor settings. If different settings are employed, the results may be meaningless. On some instruments, it may be possible to program the desired settings in a user-specified file. When this file is later invoked, the instrument will automatically adjust all of the imaging settings to the desired values. Use of such a file will greatly simplify machine setup for performing the tests, and should eliminate even minor differences in the settings which can be a cause of variability in the test results. Finally, during QC tests, one should be consistent when pairing a particular transducer with the ultrasound unit being tested (i.e., check the serial numbers) because ultrasound transducers sometimes "float" from unit to unit in departments that have more than one scanner from a single manufacturer.

B. Determining baseline values

To determine the baseline value for each image quality indicator:

- (1) Scan the phantom using the control settings listed on the

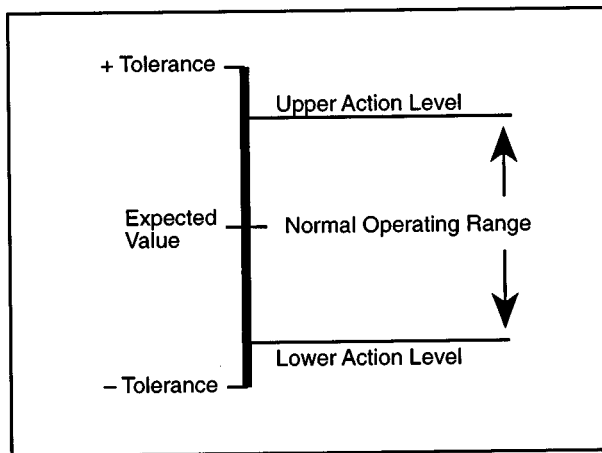

FIG. 1. Action levels are placed inside of the tolerance limits to ensure that corrective action occurs before defective quality levels are reached.

data sheet. Adjust the depth and focal zone settings as needed and record these settings on the data sheet for future tests.

- (2) Perform the test exactly as described in the test section and immediately record the measurement values on the data sheet. Save all hard copy images and label them as "baseline images." Clearly write the ID and measurement data on each image for future reference.

C. Selecting the action levels

The action level indicates the image quality indicator value at which corrective action should be taken. Action levels are located well within the instrument's specified tolerances (see Fig. 1) to ensure the image quality indicators never actually reach the defect levels. A value somewhere between one-half and three-quarters of the tolerance works well for most action levels. For example, if the maximum acceptable distance measurement error should not exceed 2%, an action level of 0.75 of the maximum acceptable error would be appropriate. If the distance tested is 120 mm, the acceptable error is $120 \times 0.02 = 2.4$ mm and the action level range would be $2.4 \times 0.75 = 1.8$ mm. The upper and lower action levels would be the expected distance of 120 mm plus or minus the action level range ($120 + 1.8 = 121.8$ mm and $120 - 1.8 = 118.2$). In some cases an image quality indicator's baseline value may not equal the expected value (e.g., 119 mm instead of 120 mm). When this occurs the action levels will not be evenly distributed around the baseline.

Recommended action levels are provided on each QC data sheet. A comprehensive list of these values is provided in Sec. IV.

IV. SUGGESTED ACTION LEVELS FOR IMAGE QUALITY INDICATORS

Table I provides suggested defect and action levels for eight phantom image quality indicators, three processor quality indicators, one video fidelity indicator, and two hard copy quality indicators used in the QA program. Please note that

these are not inflexible standards. They are guidelines to help each user establish levels appropriate for his or her particular application. Also note that some of the variability in system performance that is measured can be attributed to variability in observer rather than machine performance.

V. TEST OBJECT (PHANTOM) DESIGN AND REQUIREMENTS

The majority of the QC tests that are described in this document are performed with one or more ultrasound phantoms. Rather than promote one particular phantom design, the authors provide descriptions of alternative sections of phantoms that can be used for each test. These sections can be combined in a variety of ways to create one or more test objects. It is hoped that the act of not advocating one particular design will facilitate future phantom design innovations such as phantoms that produce images that can be readily analyzed by computers within or interfaced to ultrasound instruments. Finally, when two or more phantoms are employed for the battery of tests, it is important to be consistent with which phantom is used for each test. In other words, if two phantoms are purchased for different tests, and both happen to have a set of horizontal filaments, only one of the phantoms should be used for horizontal distance accuracy.

General requirements: The ideal phantom(s) for acceptance testing and machine intercomparison should be made of a tissue-mimicking (TM) material having the following characteristics: speed of sound = 1540 ± 10 m/s at 22 °C, attenuation coefficient = 0.5–0.7 dB/cm/MHz, and echogenicity and image texture similar to that of liver parenchyma. Unfortunately many TM materials are water-based, and some may dehydrate over time, resulting in changes in their speed of sound and attenuation characteristics. Thus, they may not be suitable for long term consistency checks unless an effective phantom maintenance program is in place.

Recent advances in manufacturing technology have resulted in better sealed phantoms which has reduced but may not have eliminated the dehydration problem. For consistency checks over several years, it may be effective to employ a phantom made of a more stable material that does not necessarily have the speed of sound or attenuation properties of soft tissue. Positions of filament targets in such phantoms can be adjusted to compensate for the difference between the speed of sound in the phantom material and 1540 m/s, which is assumed by ultrasound instruments. Therefore, distance accuracy can still be adequately tested. On the other hand, phantoms having speeds of sound different from 1540 m/s will result in inaccurate focusing of the ultrasound beam. This is related to the fact that focusing is frequently accomplished by using variable delay lines in the transducer element transmit and receive circuits that assume a speed of sound of 1540 m/s. Furthermore, the ultrasound beam divergence and pulse length are both functions of the speed of sound and the frequency dependent attenuation in the phantom medium. Hence, non-tissue-mimicking phantoms cannot very accurately assess any property of a system that is related

TABLE I. (A). Values for quick scan tests plus hard copy and display monitor fidelity. (To be performed every six months on most units, every three months on portables and emergency room units. These tests are conducted using the most frequently employed transducer.) (B). Values for less frequent tests. (These tests plus those listed in Table I(A) should be performed during an annual QC survey, when acceptance testing a unit, before a unit goes off a service contract, or when assessing a unit for possible replacement.) (C). Values for automatic film processor tests. (Ideally, these tests should be performed daily.)

(A) Image quality indicator	Suggested defect level	Suggested action level
Display monitor fidelity	# gray bars displayed < control value -3	# gray bars displayed < control value -2, fuzzy or blooming annotation (letters)
Image uniformity	In general, nonuniformity ≥ 6 dB or, any consistent measurable change from baseline.	In general, nonuniformity ≥ 4 dB or, any consistent measurable change from baseline
Depth of visualization	Change ≥ 1 cm from baseline	Change ≥ 0.6 cm from baseline
Hardcopy fidelity: Number of gray levels	Number of gray levels in hard copy is less than baseline by three or more	Number of gray levels in hard copy is two less than baseline
Hardcopy fidelity: Densities of Four gray bars (lowest, highest, and two in-between)	Any density ≥ 0.3 OD from baseline	Any density ≥ 0.2 OD from baseline
Vertical distance accuracy	Error ≥ 2 mm or 2%	Error ≥ 1.5 mm or 1.5%
Horizontal distance accuracy	Error ≥ 3 mm or 3%, whichever is greater	Error ≥ 2 mm or 2%, whichever is greater.
(B) Phantom image quality indicator	Suggested defect level	Suggested action level
Anechoic object Imaging	Major distortion or any consistent measurable change from baseline	Major distortion or any consistent measurable change from baseline
Axial resolution	In general > 1 mm, or any consistent measurable change from baseline	1 mm, or 2 mm if freq < 4 MHz, or any consistent measurable change from baseline
Lateral resolution	$3.5 \times$ focal length/(freq in MHz \times aperture diameter in mm) or change < 1.5 mm from baseline value	$2.5 \times$ focal length/(freq in MHz \times aperture diameter in mm) or change > 1 mm from baseline value
Dead zone	10 mm for $f < 3$ MHz 7 mm for $3 \text{ MHz} < f < 7 \text{ MHz}$ 4 mm for $f \geq 7 \text{ MHz}$ or any consistent measurable change from baseline	7 mm for $f < 3 \text{ MHz}$ 5 mm for $3 \text{ MHz} < f < 7 \text{ MHz}$ 3 mm for $f \geq 7 \text{ MHz}$ or any consistent measurable change from baseline
(C) Processor quality indicator	Suggested defect level	Suggested action level
Density of mid-density step (step having density closest to 1.20 OD)	Mid-density ≥ 0.2 OD from baseline	Mid-density ≥ 15 OD from baseline
Density difference (density of step closest to but not less than 2.2 density of step closest to but not less than 0.45)	Density difference ≥ 0.2 OD from baseline	Density difference ≥ 0.15 OD from baseline
Base plus fog	Base plus fog value that is more than 0.03 OD greater than baseline	Base plus fog value that is 0.03 OD greater than baseline

to focusing or pulse length such as lateral and axial resolution and cyst fill-in. Nevertheless, once a baseline image is obtained with such phantoms, the phantoms can still be used to test for consistency (i.e., precision rather than accuracy) even in these properties.

Other desirable phantom characteristics regardless of whether the phantom material is TM or not include: (a) any cystlike structures should be free of scatterers and either have attenuation less than or similar to that of the surrounding material, and (b) any filament targets should be of a material and size combination that exhibits minimal reverberation artifacts. For example, if nylon filaments are employed, these filaments should be 0.1 mm in diameter to avoid reverberations for the full range of ultrasound transducer frequencies (e.g., both above and below 5 MHz). For systems that only employ transducers that operate below 5 MHz, 0.3-mm-diam nylon filaments should be adequate.

Special note for testing prostate scanners and some water path mechanical scanners: Tests of prostate scanners with conventional QC phantoms can be significantly compromised by the presence of severe interference in the images due to the scanning of air in part of the field of view. To minimize this interference, use a soft standoff over the test object and/or scan head or place a large amount of ultrasound scanning gel on the scan head. This is also necessary with some water path mechanical scanners.

VI. COMPUTERIZED IMAGE ANALYSIS

More quantitative and definitive QC test results can be obtained with the aid of computerized analysis of the ultrasound images. It is anticipated that in the near future, most ultrasound instruments will incorporate facilities for performing such image analysis. Alternatively, a workstation consisting of a frame-grabber, computer, and software package, such as the UltraIQ Workstation marketed by RamSoft (Rexdale, Ontario, Canada), can be interfaced to an ultrasound system for off-line image analysis. A primary advantage of such workstations is that because they digitize video signals, they can be interfaced to virtually all ultrasound instruments. Also, they enable one to use identical analysis methods on images produced by different machines. A potential disadvantage is possible degradation of the images being analyzed due to possible sampling errors, electronic noise, etc., associated with the image capture process. Before employing one of these systems for ultrasound QC tests, it is advisable to use a set of test patterns to verify that the frame grabber creates minimal image degradation.⁷

In addition to the distance measuring tool that is present on all ultrasound instruments, some of the computerized image analysis tools that are needed for ultrasound QC tests include: (1) line profiling with the computation of the full width at half-maximum and full width at tenth-maximum of the pixel amplitudes along user specified horizontal and vertical line segments, and (2) region of interest (ROI) evaluation with the computation of the mean and standard deviations of the pixel amplitudes within user specified areas in the images.

Recently, Rownd *et al.* described a method for computerized assessment of ultrasound system performance.⁸ In brief, they developed a very sophisticated technique for computing lesion signal to noise ratios in images of phantoms containing tissue-mimicking spherical lesions. A computer program they wrote automatically analyzes the ultrasound images to determine the depth ranges over which lesions of specific diameters and material contrasts are detected. Automated analysis techniques like this could be incorporated in a QC program and may increase test sensitivity because they eliminate the variability in the results due to variability in human observer performance.

VII. QUALITY CONTROL TESTS

A. Frequently performed quality control tests

Following are descriptions of the quick scan tests and the physical and mechanical inspection. To complete these tests in an efficient manner, it is advised that the tests be performed in the order presented.

1. Physical and mechanical inspection

The physical condition of the scanner's mechanical components should be evaluated routinely. Some of the basic items are described below. The user's manuals and the service engineer for the unit should provide a full set of items to periodically check and maintain.

Transducers: Check cables, housings, and transmitting surfaces for cracks, separations, and discolorations. Transducer plug-ins should be marked if they can be plugged into one of several outlets. Inserting the plug and securing the transducer should be an easy operation. Bent or loose prongs may justify transducer repair.

Check mechanical transducers for the presence of air bubbles in the scan heads. Verify that the transducer(s) within the scan head move(s) smoothly without excessive noise or vibration.

Check that the edges of the material on the face of the transducer are not loose.

Power cord: Check for cracks, discoloration, and damage to the cable and plug.

Controls: Check for dirty or broken switches and knobs, and burnt out lights.

Video monitor: The video display monitor should be clean and free of scratches. Brightness and contrast controls should function smoothly and be set at proper levels.

Wheels and wheel locks: Check that all wheels rotate freely and that the unit is easy to maneuver. Check that wheels are seated securely and check wheel locks to verify that they lock securely.

Dust filters: Inspect the dust filters. They should be clean and free of lint and clumps of dirt. Dirty filters cause overheating which shortens the life of electronic components. Whoever is responsible should clean or replace the filters at regular intervals.

Scanner housing: Check for dents or other "cosmetic" damage to the scanner. These indicate events that could cause damage to the internal electronics.

Action: Take damaged systems or components out of service and repair them before using the system to image patients.

2. Display monitor setup and fidelity

Ultrasound images are viewed either directly on television monitors or on hard copy films produced with image cameras/printers. It is important to realize that the monitor and printer devices operate independently of one another. Therefore, any changes made to the monitor display will not be reflected in the printout, and vice versa. Consequently, both devices must be appropriately set up and monitored.

Many ultrasound units have “built-in” or internally stored grayscale test patterns that can be used for display setup. Examples include the SMPTE pattern⁹ and the grayscale step-wedge pattern. Such patterns should not be used in isolation. Clinical images should also be examined. Setting up the displays for the first time, to establish the operating levels, is best done with the advice of one or more radiologists and sonographers to ensure that the levels are clinically acceptable.

The display monitor and fidelity test can be divided into two sections—initial setup and follow-up. In initial setup, the monitor contrast and brightness controls are adjusted to the clinician’s liking and the number of grayscale steps displayed is noted. The follow-up consists of verifying that the baseline number of steps are displayed and that the monitor focus remains adequate.

Procedure (initial setup):

- (a) Display the grayscale test pattern.
- (b) Turn down the brightness and contrast knobs to their lowest positions (this is usually a counterclockwise direction and will result in a completely dark display). Slowly increase the brightness until the image is barely visible (make sure the room lighting matches the “normal” viewing conditions, i.e., dimmed lighting). Next, slowly increase the contrast level. Continue increasing the contrast until the text on the display starts to distort (it will gradually start to smear in one direction—usually to the right). At this point, turn the contrast down slightly until the text is no longer distorted. Most of the steps on the grayscale test pattern should now be visible, and the monitor is optimized for that pattern. (For the SMPTE pattern, the 5% and 95% contrast patches and low contrast resolution patterns should all be visible.)
- (c) Recall (or generate) a clinical image to verify that the displayed image is adequate. (If possible, before performing this test, have the clinicians store a clinical image that they feel contains many of the subtle details they wish to see, and use this image for baseline setup and follow-up tests. To ensure that the reference clinical image is of high quality, verify that appropriate log compression, preprocessing, and postprocessing settings on the ultrasound instrument are employed.) Have one or more of the clinicians review the image on the monitor with the new brightness and contrast settings.

If the clinical image is not acceptable, the monitor controls will have to be readjusted. Slowly turn the brightness and contrast knobs, one at a time, until the clinicians are satisfied with the image quality. Enter the final contrast and brightness knob positions on the TV monitor QC sheet. Mark the positions on the TV monitor and, if possible, lock the knob positions.

- (d) Once the clinicians have concurred that clinical image quality is adequate, recall the step-wedge grayscale test pattern and make a hard copy. On the TV monitor QC sheet, enter the number of steps that can be distinguished on the display. This is the baseline value. The hard copy should display the same number. If not, make the necessary adjustments to the hard copy device. Also verify the hard copy fidelity of an ultrasound image of a phantom (see QC test 5). (For systems that display a sufficient number of grayscale steps, note the first and last steps that can just be distinguished both on the display and on the hard copy—see additional notes, below.)

Procedure (follow-up QC tests):

- (a) Verify that the contrast and brightness knobs on the display monitor are set at their baseline positions.
- (b) Display the grayscale test pattern (e.g., step-wedge).
- (c) Count the number of grayscale steps that are visible on the TV monitor, and enter this number on the TV monitor QC test form. (For step-wedges that contain a sufficient number of steps, note the first and last steps that can just be distinguished.) In addition, compare the overall displayed image brightness and contrast to that observed in the baseline hard copy image.
- (d) Examine the alphanumeric information on the display monitor. It should be sharp. Blurriness may be due to aging of the TV monitor, which will also result in unsharp ultrasound images. To further isolate the source of blur, compare the crispness of detail in the displayed image with that in a hard copy. If the hard copy device is a laser printer and both the display and hard copy imagers are blurred, image degradation is due to a component other than the display. For all types of hard copy devices, if the hard copy is crisp and the display is blurred, the display is the source of the problem. Try adjusting the focus on the monitor. If this does not resolve the problem, the monitor may need to be replaced.

Suggested performance criteria and corrective action:

The number of grayscale steps displayed on the monitor should not decrease by more than 2 from the control value. If the number decreases by 3 or more steps and adjustment of the monitor brightness and contrast knobs does not correct the problem, the service engineer should be contacted. If displayed text is blurry, and adjustment of the monitor focus control fails to make the text crisp, the service engineer should be contacted.

Additional notes: The baseline hard copy can be used as a reference to check the monitor in all postbaseline tests.

Therefore it is imperative that both the display and the hard copy cameras be set up at the same time. Subtle changes in monitor brightness and contrast might be better detected by using step-wedge patterns that include a large number of steps, and noting the first and last step that can just be distinguished rather than just the total number of visible steps. A more quantitative measure of the monitor's contrast and brightness performance can be achieved by using a photometer to measure the luminance of specific grayscale patches in the displayed test pattern. Many individuals do not realize that adjusting the monitor has no effect on the hard copy device, and therefore they are surprised when their films look different from the displayed image. The best approach may be to have the contrast and brightness knobs physically removed from the ultrasound unit, thereby avoiding any temptation by the radiologist or technologist to adjust knobs. However, consultation with the ultrasound staff is suggested before taking this approach.

3. Image uniformity

Ultrasound systems can produce various image artifacts and nonuniformities. Image nonuniformities are a problem because they can mask subtle variations in tissue texture and increase the risk of false negatives. Major nonuniformities should be corrected immediately. Even though one can often "work around" minor nonuniformities, these defects should be seen as a potentially large problem and should also be corrected if consistently present.

Nonuniformities may be caused by hardware malfunctions such as bad transducer elements or poor electrical contacts in cables or circuit boards. Failures in the image processing circuitry and/or software bugs can also introduce nonuniformities. Poor acoustic coupling between the patient and transducer may also introduce reverberations and other artifacts.

Image uniformity is assessed by scanning a uniform region of a tissue-mimicking phantom and identifying any deviations from the expected smooth tissue texture.

Phantom section for this test: The phantom section for this test should be made of TM material or other material that produces a uniform texture similar to that of liver parenchyma, and be relatively free of filament and lesion-simulating targets.

Setup Use the baseline settings on the data sheet if available. Suggested settings:

- Generate images using both single and multiple focal zones.
- Adjust the gain and TGC for moderate image brightness, uniform with depth. (Brightness should be comparable to that of a typical clinical image.)

Note: Record the settings for future use.

Procedure:

- Scan across the phantom and freeze the image while moving the transducer.
- Examine the image for streaking. (See Fig. 2, below.)

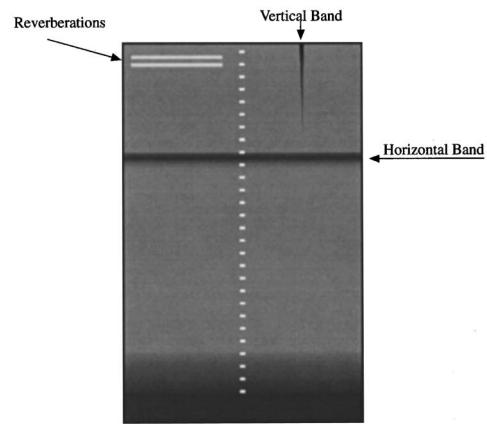

FIG. 2. Examples of common streak nonuniformities. Horizontal bands are often caused by circuitry and focusing problems while vertical bands indicate a damaged transducer element. Drawing (top) and ultrasound image (bottom) illustrating streak nonuniformities. The horizontal streaks in the bottom image are indicated by the open arrowheads that are located on the right-hand side of the phantom.

- If streaking is present, repeat the scan at another phantom location to ensure streaking is not a result of poor coupling or phantom artifact. Also, try changing focal zones and/or selecting fewer or more focal zones to determine if these have an effect on horizontal streaking.
- If the repeated scans do not eliminate streaking, store and photograph the image displaying the streak. Note the gain and output settings and the gray level of the streak. Adjust the gain or output to bring the signals adjacent to streak to the original gray level of the streak. Refer to the stored image or the developed photograph in order to more accurately adjust the gain or power settings for the desired match in gray levels. Record: Image nonuniformity=new gain or output setting-original setting.

Suggested performance criteria and corrective action: Contact one's service engineer if there are any significant nonuniformities. (The term "significant" is subjective. Each user must select their own threshold above which they con-

sider a nonuniformity significant. A threshold of 4 dB might be reasonable.)

4. Depth of penetration/visualization

The sensitivity of an ultrasound instrument determines the weakest echo signal level that can be detected and clearly displayed. In practical terms this translates into how far one can "see" into the patient, i.e., the maximum depth of visualization. The maximum depth of visualization is limited by the frequency of the transducer, the output power, gain, TGC, focal depth, display format (number of scan lines), and electrical noise of the system electronics.

The maximum sensitivity or depth of visualization is ascertained by measuring the depth in a tissue-mimicking phantom at which usable echo information disappears.

Alternative phantom sections for this test: Possible phantom sections for this test include the following.

- (i) A uniform TM section having an attenuation coefficient of 0.7 dB/cm/MHz. This section should be several cm wider than the transducer and extend to a distance of about 18 cm so depth of visualization can be analyzed for low as well as high frequency transducers. The section might include a column of filament target "depth markers" that are oriented perpendicular to the scan plane and are located at 1 cm intervals.
- (ii) A similar TM section that includes a number of anechoic (cystlike) cylindrical structures of various sizes distributed throughout. For example, the phantom might contain 1-mm-diam anechoic cylindrical objects to a depth of 2 cm, 3-mm-diam anechoic cylindrical objects from 2 to 10 cm, and 5-mm-diam anechoic cylindrical objects from 5 to 18 cm. (See Appendix C.)
- (iii) One or several similar TM sections that have spherical objects distributed in vertical planes. These objects could be anechoic (cystlike) or have echogenicity that is a set dB (e.g., 15 dB) less than that of the background. Each plane would include objects of only one size. For example, one vertical plane might include 3-mm-diam spheres, a second 4 mm, and a third 5 mm.
- (iv) Similar TM section(s) containing cylindrical plugs that are anechoic or are a set dB less than the background. These plugs are an alternative to the spherical targets. The lengths of the plugs can be adjusted so that the target shapes closely match the point spread functions achievable with most ultrasound instruments.

The advantages of the latter three designs are that they permit one to determine the maximum depth at which one can perceive an object. This eliminates some of the subjectivity involved in estimating the maximum depth of the ultrasound texture (speckle) pattern, as required with the first design.

Setup. Prior to performing this test, one should verify that

the display monitor contrast and brightness settings are correct (see Sec. VII A 2). When performing this verification and all subsequent tests, also be sure to dim the room lights in order to achieve optimum displayed image quality. Then, adjust system output and gain, TGC, persistence and the focal zone so as to obtain a relatively uniformly bright image that displays background texture echoes to as great a depth as possible. Use the baseline settings on the data sheet if available.

Suggested settings (may need to be adjusted for desired image uniformity):

- (a) Deepest focal zone.
- (b) Gain and output power at maximum.
- (c) TGC at full gain where signal begins to fall off and beyond. Note: For systems that employ sliders to set the TGC, it may be useful to create a cardboard template to indicate the slider positions. This template can then be used in subsequent tests to ensure accurate reproduction of TGC settings. For systems with knobs, it may be necessary to mark north, south, east, and west locations, and to note the position of the knob relative to those locations. Users might also consider adding ruled labels to the instrument case adjacent to the knobs or sliders.
- (d) Reject off or at minimum.
- (e) Field of view at value that permits maximum depth of visualization.

Note: Record all settings for future use.

Procedure:

- (a) Scan the phantom and freeze the image. (If possible, include a gray bar pattern along with the image.)
- (b) Measure and record the maximum depth of visualization of background echoes from the phantom. This is the distance from the top of the scan window to the deepest cylindrical or spherical object that is barely visible, or to the depth at which the background texture can barely be seen reliably. To obtain precise estimates of this distance, apply the instrument's calipers to the phantom image. Place one caliper cursor at the top of the phantom and the second straight down at the maximum depth that can be visualized. (See Fig. 3, below)
- (c) Photograph the display and process the film, leaving the display frozen.
- (d) Measure the penetration visible on the film.
- (e) Check and record whether the *processor QC* has been performed and the processor is functioning properly.

Suggested performance criteria and corrective action: Contact the service engineer if either the depth of visualization measured on the monitor or hard copy changes from its baseline value by more than 0.6 cm.

Additional notes: Use of appropriately designed phantoms containing cylindrical or spherical objects will permit one to determine the range of depths over which an object of a particular size can be perceived for a given imaging condition (e.g., transducer type and frequency, focal zone, and TGC, gain, dynamic range, and output settings).

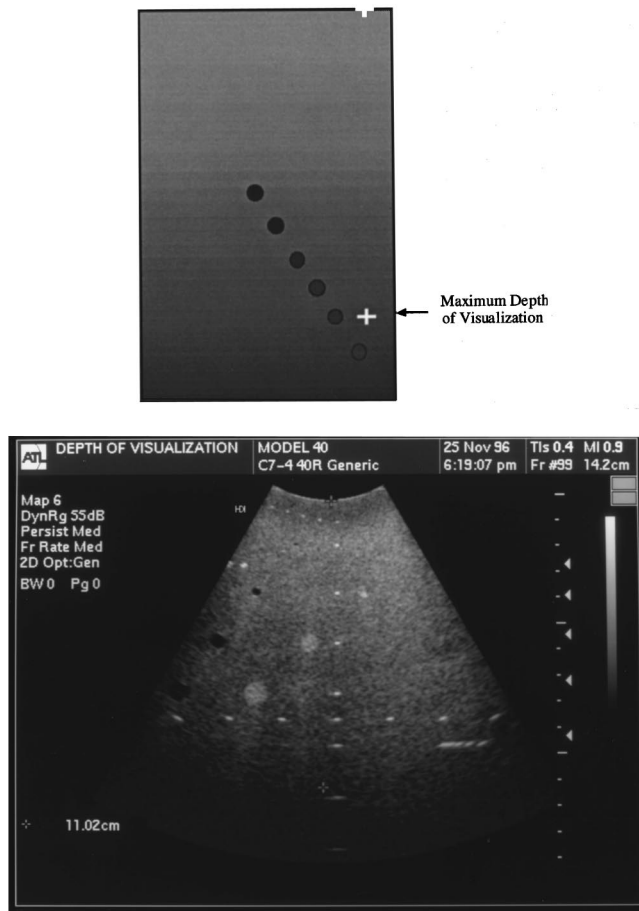

FIG. 3. The maximum depth of visualization is the point at which usable tissue echoes disappear from the image or the point at which cylindrical or spherical objects can no longer be perceived. Drawing (top) and ultrasound image (bottom) illustrating measurement of the maximum depth of visualization or penetration by means of anechoic objects (top) and usable texture (bottom).

Electronic noise can be distinguished from the texture pattern by the fact that when the transducer is held stationary over the phantom, the texture pattern is constant, whereas the electronic noise pattern is changing.

Computer analysis of the mean and standard deviations of the gray levels as a function of depth in a uniform phantom section may yield more quantitative estimates of the depth of visualization. The mean gray level would be expected to decrease and the standard deviation increase significantly at the limit of visualization. Similarly, computer analysis of the signal to noise ratio for simulated cysts [(mean gray level in cyst-mean gray level in background)/standard deviation of background] at different depths could be used to better quantify the depth of visualization. The signal to noise ratio continuously diminishes beyond the maximum depth of visualization.

The maximum depth of visualization should remain constant over time; variations indicate performance degradation. Changes in the depth of visualization can be caused by variation in output intensity and receiver gain as well as damage to the transducer or cable.

5. Photography (hard copy) fidelity

The fidelity of the photographic recording is checked with respect to shades of gray and weak and strong echo texture by comparing the display with the final hard copy image. Tests of hard copy distortion and cyst perception are contained in the tests of distance accuracy and anechoic object perception described later in this paper. Problems such as drifting multifformat cameras can be tracked on systems that generate gray bar patterns by employing a densitometer to measure the optical densities of several of the gray bars, and plotting the results as a function of time.

Procedure:

- Check and record whether the *processor QC* has been performed and the processor is functioning properly. If the processor is OK, proceed with the following.
- If the ultrasound system produces a full image grayscale test pattern, display this test pattern, and generate a hard copy.
- Compare the number of gray bars visible on the TV monitor with the number visible on the film. Compare these values with those obtained at baseline.
- Scan the ultrasound phantom as described in Sec. VII A 2, above. Most systems offer the option of displaying a thin gray scale bar pattern to the side of the US image. Include this pattern if possible, and generate a hardcopy. Keep the image of the phantom on the display so it can be compared with the hardcopy.
- Compare the number of gray bars visible in the thin grayscale bar pattern on the TV monitor with the number visible on the film. Compare these values with those obtained at baseline.
- Verify that the weakest echoes on the display are visible on the film.
- Verify that the small gaps of nearly full brightness between very strong echoes are as visible on the film.
- Use a densitometer to measure the optical densities of four of the gray shades in the hard copy of the full-image grayscale test pattern. The gray shades to measure are the lightest, the darkest and two spaced equally between. Compare these densities to those measured at baseline.

Suggested performance criteria and corrective action:

Contact the service engineer if the number of gray levels in the hard copy is less than the baseline value by 2 or more. Contact him or her if any of the optical densities of the selected four gray shades in the hard copy differ from baseline by greater than 0.2 O.D. (assuming the sensitometry tests show the processor is working properly). (See processor QC in Sec. VII C, below.) Service is also indicated if there is a marked change in the display of the weakest and/or strongest echoes relative to a hardcopy image obtained at baseline.

Additional note: To minimize QC test time, operators may find it advantageous to combine the hard copy test with the depth of penetration test described above.

6. Distance accuracy

Distance measurement errors are not always obvious and can easily go unnoticed. The vertical distance or depth calibration test determines the accuracy of measured distances along the beam's axis. Vertical distance errors can be caused by drift or failure in the system's internal timing circuits, and are far less likely to occur than horizontal caliper inaccuracies. The horizontal test assesses the accuracy of measurements perpendicular to the beam axis. Horizontal distance errors can be the result of flaws in the transducer scan mechanism, and thus are particularly important for mechanical real-time transducers, including annular arrays, where motor wear can distort accuracy.

Distance accuracy is assessed by comparing the measured distance between selected filament targets in a phantom with the known distance. The test distance used should correspond with the distances normally measured in one's studies.

Phantom section for this test: The phantom section should include a vertical column of filament targets that are oriented perpendicular to the scan plane and are located at 1 cm intervals. It should also include several horizontal rows of filament targets separated by known (e.g., 3 cm) distances. Ideally, this phantom section should have a speed of sound of 1540 m/s. If it has a different speed of sound, the spacings between the targets should be modified by the manufacturer to produce the desired 1 and 3 cm separations when the phantom section is imaged with a calibrated ultrasound instrument.

Setup. Use the same scanner setup as in the depth of visualization test.

Procedure

- (a) Scan the phantom so that the vertical column of filament targets appears toward the center of the image and a desired set of horizontal targets is also visible (see Fig. 4). When performing this scan, position one of the electronic focus zones at the depth of the horizontal targets. Also, be sure to use as little pressure as possible when applying the transducer to the scanning membrane. Pressing too hard can displace the filaments in the phantom resulting in measurement errors [see Fig. 4(B)]. Also, be sure to align the scan head so that the scan plane is perpendicular to the filaments. This usually requires aligning the scan head parallel to the long side of the phantom. [Figure 4(C) shows an apparent error in the measured horizontal distance caused by rotation of the transducer.] Freeze the image (include the distance markers) and photograph.
- (b) *Vertical distance accuracy*
 - (b1) Use the ultrasound instrument's calipers to measure the distance between the most widely separated filament targets in the vertical column displayed in the image. Place each caliper marker or cursor at the top of the echo from the filament rather than through the center or at the bottom. Be sure to measure the distance displayed and not the distance expected! Always measure the distance between the same two filaments as in the baseline tests. Enter the measured

value on the "vertical distance accuracy" data sheet. (b2) Use whatever method is commonly employed at the facility to measure the corresponding distance on the photographed image. (The scale factor for this distance is normally the ratio of the known distance between the distance markers on the side or top of the image to the corresponding length measured on the film with a ruler.) Enter the measurement on the "vertical distance accuracy" data sheet.

- (c) *Horizontal distance accuracy*
 - (c1) On the frozen image, place the caliper markers above (or below) the centers of the echoes of the desired filaments (Fig. 4). Always measure the distance between the same two targets that were used during the baseline tests. Enter the measured value on the "horizontal distance accuracy data sheet."
 - (c2) Measure the corresponding distance on the photographed image and enter that value on the same data sheet.

Suggested performance criteria and corrective action. Consider contacting one's service engineer if:

- (1) Vertical measurement error is greater than 1.5 mm or 1.5% of the actual distance.
- (2) Horizontal measurement error exceeds the greater of 2 mm or 2% of the actual distance.

Additional notes: Measurements made off the hard copy (photograph) may differ significantly from those made with the cursors on the machine if there is a large amount of geometric distortion in the video monitor associated with the hard copy device. Discrepancies greater than 2% should be corrected at the next service visit.

Any discrepancies in the machine caliper measurements that are greater than the above values are probably the result of either machine error or the incorrect velocity of ultrasound in the phantom. A second phantom is helpful in determining the source of this problem. If the distance measurements are erroneous for both phantoms, then the ultrasound unit is most likely at fault. If the distance measurements for only one phantom are erroneous, then the phantom is probably at fault. The velocity of ultrasound in the phantom is sensitive to temperature fluctuations ($\Delta c/\Delta T \sim 1.5$ m/s per °C). A second ultrasound unit could be tested if only one phantom is available.

B. Less frequent quality control tests

1. Anechoic object imaging

The anechoic object (cyst) imaging test examines the system's ability to detect and accurately display round, negative contrast objects of various sizes. This test combines aspects of spatial and contrast resolution and image uniformity into a single test. Anechoic object image quality can also be affected by electrical noise, side lobes in the transducer beam, and problems in the image processing hardware.

Alternative phantom sections for this test: The phantom sections for this test could be of either the cylindrical, cylindrical plug, or spherical anechoic object varieties described

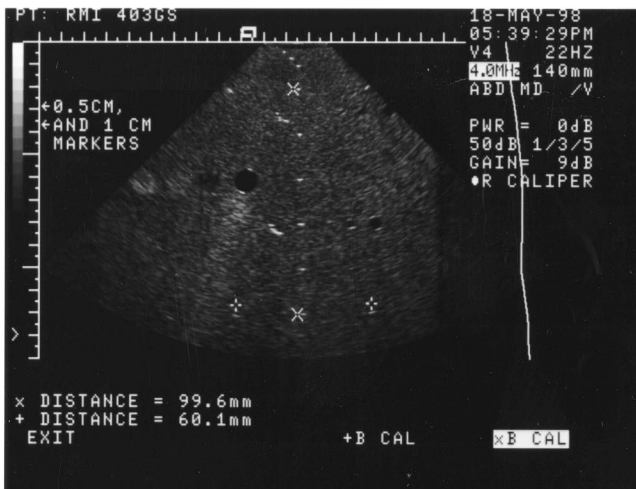

(a)



(c)

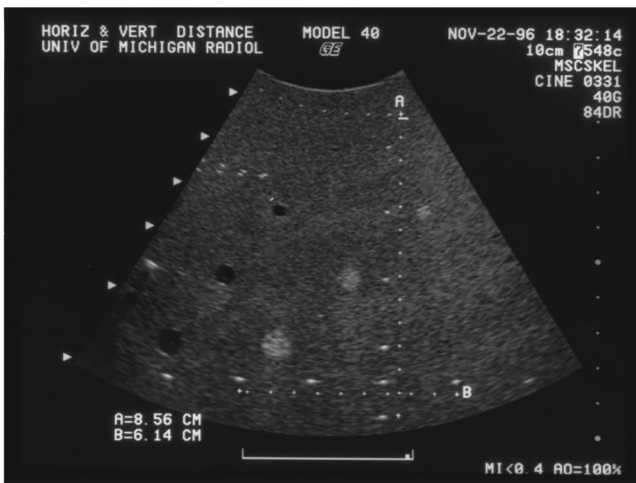

(b)

Fig. 4. (a) Image demonstrating correct positioning of cursors for horizontal (+) and vertical (x) distance measurements. (b) Vertical and horizontal distance measurements made with a QC phantom. The true distance between the chosen filaments for the vertical measurement is 9 cm, and the true distance for the horizontal measurement is 6 cm. Corresponding measured values were 8.56 and 6.14 cm. Nearly identical values were obtained with the same phantom on a different ultrasound unit. The similar errors in the vertical direction seemed to indicate there was a problem with the phantom—either the filament positions or the speed of sound may have been incorrect. However, when the results were discussed with the phantom manufacturer, they suggested the operator’s pressing down on the phantom with the transducer while performing the scans could have caused the error. The measurements were repeated using water in a trough on top of the phantom as the transducer coupling medium and almost no pressure. This time, a correct vertical measurement of 9 cm was obtained. Care should be taken to apply as little pressure as possible to the scanning membrane when performing this test. (c) Horizontal distance measurement made with the long axis of a curvilinear array transducer rotated so the scan plane intersects the filaments in the phantom at an angle of about 75 degrees rather than 90 degrees. Such incorrect positioning of the transducer will result in a measurement error equal to the true distance multiplied by $((1/\sin(\text{angle})) - 1)$ (e.g., $6\text{ cm} \times ((1/\sin(75)) - 1) = 0.21\text{ cm}$).

in the “maximum depth of visualization” test. The spherical anechoic objects more closely simulate cysts; whereas, the cylindrical anechoic objects more closely simulate large blood vessels. Short cylindrical plugs are similar to spherical cysts. Longer plugs represent a middle ground between spherical cysts and large blood vessels.

Setup: Use the baseline settings on the data sheet if available:

Suggested Settings:

- (a) Multiple focal zones (e.g., 3, 7, 11 cm) or set single focus at these depths.
- (b) Adjust gain, power, and TGC to display maximum number of anechoic objects.
- (c) Record settings for future use. (Be sure to record the gray-level map and dynamic range used since these parameters affect cyst fill-in.)

Note: Record settings for future use.

Procedure:

- (a) Scan the phantom.

- (b) Record the smallest anechoic object that can be visualized at specific depths (e.g., 3, 7, and 11 cm), or record the depth range over which anechoic objects of a particular size can be perceived. (Note: This information will already have been acquired if this phantom section was employed for the maximum depth of visualization test. If so, proceed to the following after performing that test.)
- (c) Grade the quality of the images of anechoic objects that are just larger than the smallest that can just be perceived. (e.g., *c* = clear, *f* = filled in, *J* = jagged edge, *N* = no enhancement distal to the anechoic object.) (See Fig. 5 for some examples of normal and abnormal images of anechoic objects.)

Use the instrument calipers to measure the height and width of the anechoic objects. (The height and width should be the same.) Record the ratio of height divided by width.

Note: At least one dimension should be correct, or the operator may not have scanned the cyst through

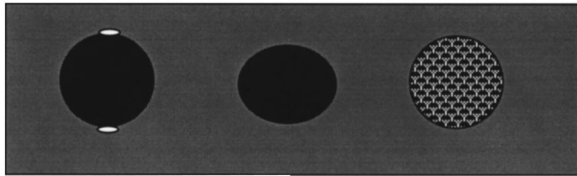

FIG. 5. (Left) The normal appearance of an anechoic object. Notice the sharp edges, clear black appearance, and round shape. Bright artifacts at the top and bottom are normal specular reflections. (Center) Flattened anechoic object indicates geometric distortion. (Right) Echoes inside the anechoic object may be the result of system noise or side lobe contamination.

the middle. If neither dimension is correct, yet caliper accuracy was correct, then rescan and repeat the evaluation.

- (d) For one or more of the larger anechoic objects that display fill-in, decrease the gain of the ultrasound instrument until the fill-in disappears. Record this new gain level and compare it to the one(s) employed at baseline.

Suggested performance criteria and corrective action:
Contact one's service engineer if:

- (1) the anechoic objects display major distortion (e.g., height differs from width by 20% or more);
- (2) there is any consistent measurable change from baseline.

Additional notes: Because the majority of this test is subjective, images from previous tests should be used for comparison.

Bright spots at the top and bottom of the anechoic objects are specular reflections and are normal for some systems. Posterior enhancement also depends upon equipment and phantom factors and may or may not be present.

Computer calculation of the signal to noise ratios of the anechoic objects may be employed for a more quantitative assessment of anechoic object perception. The signal to noise ratio is computed using the equation: $SNR = (\text{average gray level inside anechoic object} - \text{average gray level in adjacent background}) / \text{standard deviation of background gray level}$.

2. Axial resolution

Axial resolution describes the scanner's ability to detect and clearly display closely spaced objects that lie along the beam's axis. (It also determines the smallest resolvable object along the beam axis.) Axial resolution depends on the transducer's spatial pulse length or pulse duration, which in turn depends on the center frequency and damping factor. In general, it is found that the higher the frequency, the shorter the pulse length and the better the axial resolution.

Axial resolution can be determined by identifying the closest two filaments in a set of axial resolution targets that can be clearly identified as separate objects in the image. Objects are said to be separate when a dark line exists between them. Axial resolution can most quantitatively be described by the full width at half maximum (FWHM) (-6 dB) and/or the full width at tenth-maximum (FWTM) (-20 dB)

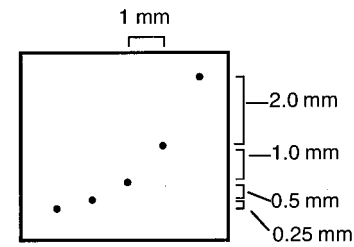

Axial resolution target group

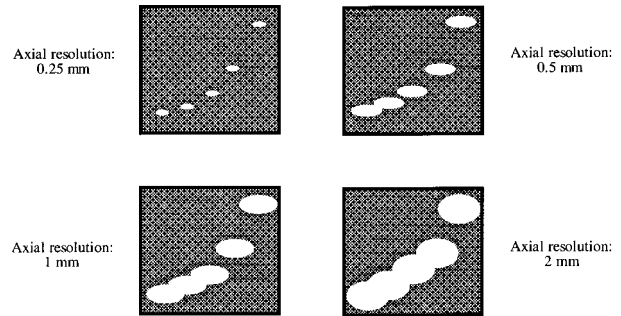

FIG. 6. (Top) Spacing of filament targets in the axial resolution target group of a phantom. (Bottom) Examples of the appearance of filament targets at varying levels of resolution.

of a profile in the axial direction of the echo amplitudes in an image of a single filament target within a low scatter medium. The preferred method is to measure the FWHM or FWTM, and this should be more universally applicable when manufacturers incorporate profile plotting and analysis packages in their ultrasound units. Unfortunately, target pair spacings in current phantoms are inadequate and permit the user to do no more than draw gross conclusions about axial resolution.

Alternative phantom sections for this test:

- (i) A phantom section containing single filament targets at specific axial distances (e.g., 2, 6, 10, and 15 cm) within a low scatter medium having a speed of sound of 1540 m/s and an attenuation coefficient of 0.5–0.7 dB/cm/MHz). The targets should also be of a variety that do not produce reverberation artifacts.
- (ii) A phantom section containing a set of filament targets that are displaced axially by known distances. See Fig. 6. Note: The targets should be of a variety that do not produce reverberation artifacts for the ultrasound transducer frequencies employed. (Targets spaced as close as 0.25 mm are available in some phantoms and are especially useful when testing small parts scanners.)

Setup: Use the same output and dynamic range settings as in anechoic object tests. Adjust gain so that background texture echoes are barely visible.

Procedure (single axial resolution targets, FWHM from profile):

- (a) Place the focal zone at the depth of the resolution target

of interest. Scan the phantom, zooming a maximum amount at the target location. In addition to focal zone position, axial resolution is also influenced by the beam intensity, gain, and TGC. Be sure to adjust these items for optimum axial resolution (texture echoes should be barely visible) during the baseline tests and record the values for future tests.

- (b) Use the profile generation and analysis facilities of the ultrasound unit or attached image analyzer. Select a vertical line passing through the center of the imaged target for the profile. Have the system generate the profile (it should look like a bell shaped curve), and compute the FWHM and/or the FWTM. The FWHM and the FWTM are both measures of axial resolution.

Procedure (filament targets in axial resolution grouping):

- (a) Scan the phantom, as above, with focus located at axial resolution target grouping of interest and with maximum image zoom at that location. Note that the results of this analysis will be highly dependent upon the machine settings (e.g., gain, dynamic range, output, etc.) employed in generating the image. Identical settings must be employed each time.
- (b) Record Axial resolution = smallest separation between targets that can be perceived at each depth. (See Fig. 6.)

Suggested performance criteria and corrective action: In general, axial resolution should be 1 mm or less for transducers having central frequencies greater than 4 MHz and 2 mm or less for transducers having central frequencies less than 4 MHz. Corresponding FWHM and FWTM values have not been established. However, an interim recommendation might be $\text{FWHM} \leq 0.45$ mm and $\text{FWTM} \leq 1$ mm for transducers having central frequencies greater than 4 MHz, and $\text{FWHM} \leq 0.9$ mm and $\text{FWTM} \leq 2$ mm for transducers having central frequencies less than 4 MHz.

Axial resolution should remain stable over time: Contact the service engineer if any changes are observed.

Additional notes: Filament targets larger than 0.15 mm in diameter may produce a doubling artifact for transducer frequencies ≥ 5 MHz.

Reasons for degraded axial resolution include damaged transducers (broken crystals, loose facing or backing material, or broken electrical connections) and changes in the pulser and/or receiver characteristics.

The axial resolution that is measured in this test cannot be directly quoted as the axial resolution that is expected in clinical scans since other factors such as organ and vessel motion and volume averaging will degrade the clinical results.

3. Lateral resolution or response width

Lateral resolution describes the instrument's ability to distinguish structures that are closely positioned within the image plane along a line perpendicular to the beam's major axis. Lateral resolution is approximately equal to beam width and varies with depth, the transducer focusing characteris-

tics, the number of scan lines (lines of sight), and the system's gain and sensitivity settings. Objects smaller than the ultrasound beam are displayed with a width equal to the width of the ultrasound beam at that depth. The lateral resolution of transducers with a fixed focus will vary noticeably with depth. Systems with multiple focal zones or "dynamic focus" may produce more uniform lateral resolution over a wider range of depths. Lateral resolution is typically affected by the loss of transducer elements or by problems in the system's beam-forming and receiving circuits.

Lateral resolution can be assessed by measuring the width of filament targets at depths corresponding to the transducer's near, mid, and far field zones. It can also be measured directly by imaging filament target groupings in which the filament targets are displaced laterally by a variety of known distances. Finally, it can be characterized by the FWHM and/or the FWTM of a profile in the lateral direction of a single target at a specific depth. The latter method is the most objective and is the one that is preferred.

Alternative phantom sections for this test:

- (i) A phantom section containing a single column of filament targets each separated axially by 1 cm.
- (ii) A phantom section containing a set of filament targets that are displaced laterally by known distances. For example, the section might include filaments separated by 2, 2.5, 3, 3.5, 4, 4.5, 5, 5.5, and 6 mm. Complete sets of targets should be located at different axial distances (e.g., 2, 7, 10, and 15 cm).
- (iii) As described above, the spherical anechoic object phantom produces an indirect measure of lateral as well as axial and elevational resolution.

Setup: Use the same output and dynamic range settings as in anechoic object tests. Adjust gain so that background texture echoes are barely visible.

Procedure: (for phantoms containing single filament targets in a vertical column):

- (a) Scan phantom in region containing vertical column of filaments.
- (b) Reduce FOV to just view filament in focal region. If possible, zoom in on that filament.
- (c) Freeze the image.
- (d) Use calipers to measure the lateral resolution or response width = width of the filament in the focal region. (Always measure the filament width from edge-to-edge as shown in Fig. 7.) Record this value.
- (e) Repeat for different focal regions. (For baseline tests, select three filaments at depths representing the near-, mid-, and far-field zones of the transducer. Record these depths on the data sheet.)
- (f) Alternatively, for systems that incorporate profiling capabilities, select a horizontal line passing through the center of the image of the filament target of interest, and have the system plot the profile and compute the FWHM and/or the FWTM. Repeat for filament targets of interest at different depths.

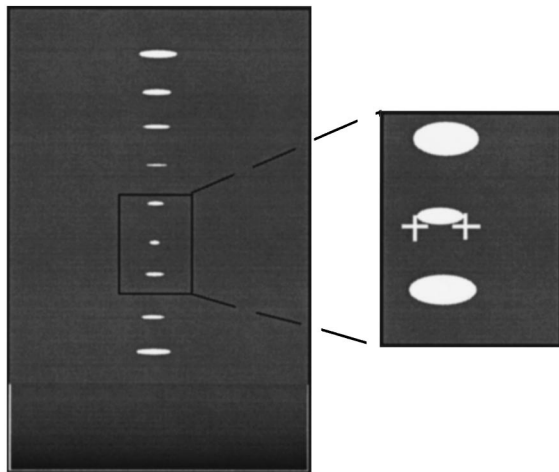

FIG. 7. The lateral resolution at a particular depth is determined by measuring the width of the filament target at that depth.

Procedure: (for phantoms containing multiple filament targets in horizontal rows):

- (a) Scan the phantom as described above.
- (b) Zoom the image in a region containing the filament targets, and determine which set can just be identified as containing two separate filaments (there should be a dark line between the filaments). This is the lateral resolution.
- (c) Repeat for sets of filaments at different axial distances from the transducer.

Suggested performance criteria and corrective action: Lateral response width should be less than $3 \times \text{focal length} / (\text{frequency in MHz} \times D \text{ in mm})$, where D is the manufacturer specified aperture width. Suggested action levels are set at $2.5 \times \text{focal length} / (\text{frequency in MHz} \times D \text{ in mm})$.

In general, the measured lateral resolutions should meet the specifications in Table II.

Although minor variations are normal, the filament width should remain relatively constant (within 1 mm) over time.

As with axial resolution, lateral resolution is highly dependent upon the machine settings that are employed in generating the image. Be sure to optimize these settings for baseline studies, and use the same settings for all follow-up studies.

TABLE II. Recommended lateral resolution requirements.

Depth (cm)	Transducer frequency (f) (MHz)	Lateral resolution		
		Response width or spacing between targets (mm)	FWHM (mm)	FWTM (mm)
>10	<3.5	≤ 4	≤ 2	≤ 4
<10	$3.5 \leq f < 5$	<3	<1.5	<3
<10	≥ 5	<1.5	<0.8	<1.5

Call the service engineer if the beam width changes by more than 1 mm for two successive test periods or if it is greater than the value computed with the above formula.

Additional notes: Theoretically, the lateral beam width of a focused transducer is approximately equal to $\lambda f\#$, where λ is the wavelength corresponding with the resonant frequency of the transducer and $f\# = \text{focal length} / \text{aperture size}$. For c equals 1540 m/s, this width is given by

$$\text{width (mm)} \approx \frac{1.54}{f(\text{MHz})} \times \frac{\text{focal length (mm)}}{\text{aperture (mm)}}$$

In practice, the measured beam width in mm should be smaller than about

$$\frac{2.5}{f(\text{MHz})} \times \frac{\text{focal length (mm)}}{\text{aperture (mm)}}$$

The specified aperture size should be employed in this equation.

4. Ring down or dead zone

The ring down or dead zone is the distance from the front face of the transducer to the first identifiable echo. No useful scan data are collected in this region. The dead zone is the result of transducer ringing and reverberations from the transducer-test object (phantom or patient) interface. Electrical impedance matching between the transducer and the pulser/receiver is essential to prevent electrical ringing (part of the excitation pulse is reflected back to the pulser). The transducer dead zone occurs either because a hard surfaced offset is used to separate the transducer from the patient or because the emitted pulse is finite in length and low amplitude echoes might not be detectable if they coincide in time with the excitation pulse complex at the transducer. Performance is consequently instrument-dependent. As frequency is increased, pulse length decreases and the depth of the dead zone decreases, if all other factors remain constant. The acoustic output also influences the depth of the dead zone. Finally, ring down observed in phantoms can differ significantly from that in patients, especially when the impedance of the phantom surface (e.g., Saran) is very different from that of skin.

Alternative phantoms or phantom sections for this test:

- (i) A phantom section containing a set of filament targets located very close to the scanning window (e.g., filament targets at depths of 1, 4, 7, and 10 mm).
- (ii) For systems incorporating computerized image analysis, a uniform phantom section may be employed for this test.
- (iii) A cylindrical anechoic object phantom produces an indirect measure of ring down. When the depth of visualization test is performed with this phantom, the beginning of the visualization range depends upon ring down as well as axial and lateral resolution.

Method for phantom section containing filament targets near scanning window

Setup:

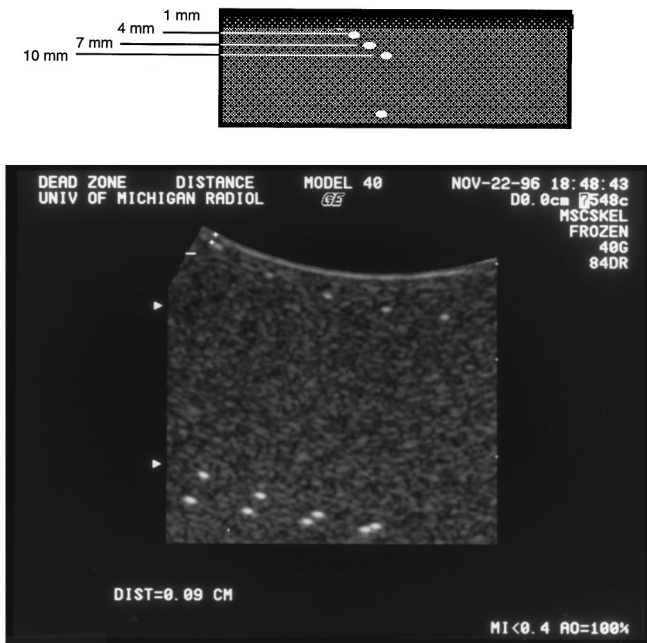

FIG. 8. The depth of an instrument's dead zone is determined by identifying the shallowest filament target that can be clearly visualized. In the pictorial representation (top) the dead zone is 4 mm deep. In the image of an ultrasound phantom (bottom), the dead zone is 0.09 cm or 0.9 mm.

Use baseline settings on data sheet if available.
Suggested settings:

- (a) Focal zone closest to scanning window.
- (b) Adjust gain so background echoes are barely visible.
- (c) Avoid excessive near gain in the TGC, but make it great enough to see some scatterers.

Note: Record settings for future use.

Procedure:

- (a) Scan the region in the phantom containing the dead zone test filaments. (See Fig. 8.)
- (b) Freeze the image and determine the closest filament that can be imaged. Record dead zone=depth of this filament. (See Fig. 8.)

Method for uniform TM phantom section and computer analysis

Setup: Use same setup as in image uniformity test.

Procedure

- (a) Scan the phantom.
- (b) Select a short, wide rectangular region of interest (ROI). Have the computer determine texture features within this ROI as the ROI is moved in the image from the top of the phantom downwards. (It will be necessary to perform separate studies to determine the best texture features for this application.)
- (c) The dead zone may be defined as the distance from the top of the phantom to the location (center of ROI) where the texture features reach the characteristic or equilibrium values for the image of the phantom.

Suggested performance criteria and corrective action. The dead zone should meet the specifications listed in Table

TABLE III. Dead zone requirements.

Transducer central frequency (f) (MHz)	Dead Zone (mm)
≤ 3	< 7
$3 < f < 7$	< 5
≥ 7	< 3

III. Contact the service engineer if the dead zone does not meet the above criteria or if there is any consistent measurable change from baseline.

Additional notes: A shift in the depth of the dead zone of the transducer reflects changes in the transducer and/or pulsing systems. Specifically, deeper dead zones can be attributed to an elongated pulse length arising from either a cracked crystal, a loose backing or facing material, a broken lens, or a longer excitation pulse. Artifacts in the dead zone may be indicative of input power fluctuations.

5. Slice thickness or elevational focus

Currently most electronically focused transducers (except annular arrays) have an out-of-slice focus that is achieved by placing an external US lens over the array. This fixed lens has a focal depth appropriate for the frequency and planned use of the transducer. For example, a small parts 5 MHz transducer will be slice thickness focused from 1.5 to 3.5 cm in depth, while a pediatric 5 MHz transducer will be focused deeper and over a greater range, usually 2.5–5.5 cm in depth. As with lateral and axial resolution, elevational resolution can be measured indirectly with the anechoic spherical object or cylindrical plug phantoms. Slice thickness focusing can also be evaluated qualitatively by scanning the anechoic cylindrical objects in an ultrasound QC test phantom with the scan plane along the lengths of the cylinders (e.g., perpendicular to the usual scan direction). Quantitative assessment can be achieved using an “inclined plane” phantom. (See Fig. 9, below.) Measurements made with the inclined plane phantom should be performed at acceptance testing and when images display more than the usual amount of fill-in of cystlike structures.

Alternative phantoms or phantom sections for this test:

- (i) An inclined plane phantom.

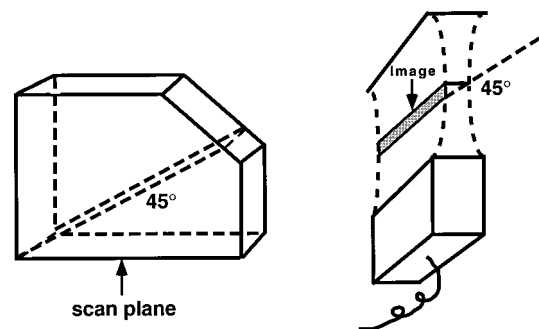

FIG. 9. Sketch of inclined plane phantom that is used to test slice thickness. Note: height of image=slice thickness width.

- (ii) As described above, the anechoic spherical object and cylindrical plug phantoms produce indirect measures of elevational as well as axial and lateral resolution.
- (iii) An anechoic cylindrical object phantom can also be used to produce an indirect measure of elevational resolution if as described above, the transducer is positioned parallel to the long axis of the cylinders.

Method for the inclined plane phantom:

Setup: Turn the inclined plane phantom upside down and start the scan from the edge closest to the incline. If multiple focal zones are available, use as many as possible, centered at 3 cm for 5 MHz and above, or 7 cm for transducers below 5 MHz in frequency. Gain, output, and TGC should be the same as for the anechoic object perception test.

Procedure: With the scan plane oriented along the short axis of the phantom (perpendicular to the usual longitudinal scan direction), slowly move the transducer along the phantom. A bright rectangle will appear at the top of the image and move down to increasing depth as one scans away from the end of the phantom. At the top of the image, the rectangle will be at least 0.6 cm deep. As the rectangle moves to greater depth, this dimension will grow smaller. Record the depth where this first occurs; continue scanning and move the focal zones deeper. When the rectangle either spreads or becomes diffuse, with no central intensity, record the scan depth again. These two measurements are the *slice thickness focal range*. Find the depth where the rectangle is narrowest. Move a single focal zone to this depth and measure the thickness of the rectangle at this depth. This is the *slice thickness*. The depth where this occurs is the *slice thickness focal depth*.

Suggested performance criteria: Spherical cysts cannot be imaged with echo free interiors if they are smaller than the slice thickness measurement at the slice thickness focal depth. When acceptance testing a unit, if the slice thickness focal depth is beyond 8 cm for a 5 MHz or higher center frequency transducer, or this depth is less than 3 cm for a 3 MHz or lower frequency transducer, the reason for such unusual foci should be considered carefully, with the idea of ordering different transducer models. Slice thickness focal range, thickness, and depth should be posted on the US unit for each commonly used transducer. Any significant variation from the posted values when retesting these parameters may signify detachment of the focusing lens and the need for transducer repair or replacement.

C. Film sensitometry

Automatic film processor conditions can have enormous effects on the quality of the final hard copy images. This fact has been recognized by the American College of Radiology (ACR), which for x-ray mammography recommends a series of processor QC tests be performed each day prior to the first patient exam. The reader is referred to pages 34 to 41 of the ACR Mammography Quality Control Manual⁶ for a complete description of the processor QC tests. Some of those tests are repeated here, and additional information is provided on how to perform the tests with laser printer hard

copy devices which are becoming more and more popular in ultrasound departments. An example is also presented to help clarify some of the subtle points involved in performing a crossover from old film values to new film values when a new batch of film is employed for quality control purposes.

The primary processor test involves exposing a control film with a sensitometer and verifying that various steps on the developed film have optical densities that are within established control limits. In addition, the temperature of the developer should be checked. One difference for laser printers is instead of creating a test film with a sensitometer, one creates the test film by recording a digitized image of a known grayscale pattern such as the SMPTE pattern.⁸ The pattern should be stored internally in the ultrasound unit.

Procedure:

- (a) For systems that employ multiformat camera hard copy devices, expose a control film with a sensitometer and immediately process that film. Note that single emulsion films are employed in most multiformat cameras that are attached to ultrasound units. Be sure to expose the emulsion side of the film with the light sensitometer, and be sure the light spectrum of the sensitometer matches the sensitivity of the film (i.e., use green light for green sensitive film and blue light for blue sensitive film). For laser printer hardcopy devices, display a digitized grayscale pattern (e.g., the SMPTE pattern) on the ultrasound unit and send the image to the laser printer hard copy unit.
- (b) Use a densitometer to measure the optical densities of the established steps on the developed film. These established steps include:
 - (1) base+fog (usually the first step on the sensitometer strip or the 100% patch on the SMPTE pattern).
 - (2) the step with a density closest to 1.20 (called the mid-density or the speed step; usually the 30% patch on the SMPTE pattern).
 - (3) the step with a density closest to but not less than 0.45 (e.g., the 70% patch on the SMPTE pattern).
 - (4) the step with a density closest to 2.20 (e.g., the 10% patch on the SMPTE pattern).
 The difference between the densities of the latter two steps is termed the density difference, and is related to the contrast of the film.
- (c) Plot the base+fog, mid-density, and density difference values on appropriate control charts and verify they are within established control limits. Circle any values that are beyond control limits and repeat the test. If values are still beyond limits, call service.
- (d) Note any trends in the data (e.g., density difference is increasing with time) and try to determine the cause of those trends.
- (e) Measure the temperature of the developer using a digital thermometer.

Suggested performance criteria and corrective action: As recommended by the ACR,⁶ the control limits are ± 0.10 OD from the operating levels for mid-density (MD) and density

difference (DD) and +0.03 from the operating level for the base+fog. So long as the measured values are within these limits, no action is required. If either the measured MD or DD is beyond ± 0.10 of the operating level, but within ± 0.15 , the test must be repeated. If the result is the same, the processor may be used, but it should be monitored very carefully. If either the measured MD or DD value differ from its respective operating level by ± 0.15 OD or more, the processor should be repaired before developing patient images. The same is true if the B+F exceeds the operating level by more than +0.03. The developer temperature should be within ± 0.5 degrees F (± 0.3 °C) of the manufacturer's specification [typically ~ 95 degrees F (35 °C)].

1. Establishing operating levels

One of the first steps in performing processor QC is the establishment of the operating levels for B+F, DD, and MD. The ACR recommends that these be established after first draining the processor and then refilling it with fresh chemicals. Once a day, for the next 5 days, sensitometer strips are exposed and optical densities read-out. The average values for B+F, MD, and DD are computed and are selected as the target operating levels. To establish operating levels that are more representative of values that occur during an entire preventive maintenance cycle (time between draining and refilling with fresh chemistry), it may be desirable to instead average values obtained for a period of 10 days consisting of the 5 days prior to and the 5 days after the chemistry is replaced in the processor.

2. Control films and film emulsion crossover

The two primary causes of hardcopy variability are variations in processor chemistry/temperature conditions and variations in film response. To isolate the processor chemistry/temperature aspect, people often perform their QC tests with a separate box of "control film." Eventually, the box of control film runs out, and it is necessary to use a different box. Before the control film box is empty, one should perform what is termed film emulsion crossover.

The sequence of events for film crossover is as follows:

- (a) Expose and process five sensitometer strips of the "old" control film.
- (b) Expose and process five sensitometer strips of the "new" control film.
- (c) Read the B+F's, MDs, and DDs on all of the old films.
- (d) Determine the steps of the MD and DD for the new film. [The steps used for these values on the new film will almost always be the same steps as those on the old films (exceptions can result when a new type of film is used, if the film has been stored for a long period of time, or if the film has been reengineered by the manufacturer).]
- (e) Read the B+F's, MDs, and DDs on all of the new films [using the steps established in (d)].
- (f) Calculate the average B+F, MD, and DD for all of the old films.

- (g) Calculate the average B+F, MD, and DD for all of the new films.
- (h) Calculate how much the average value of the old film is "off" of the target operating value which was previously established for each of the three parameters (B+F, MD, and DD).
- (i) Subtract the difference [computed in (h)] from the average value of the new film for the same parameter—this is the new target value [e.g., if the average mid-density of the old film is 0.02 less than the operating target value (difference = -0.02), then subtract -0.02 from the average mid-density of the new film (e.g., add +0.02)—this is the new operating level which will be used for the mid-density of the new film].

Note: Plotting all of the control strip data from a crossover session on the control chart is a useful record of the transition from one film batch to another (or one film type to another). The crossover data for the new film should be plotted on a new control chart, which will then be used as the "working" control chart for the new film.

3. Example of performing a crossover

The following is an example of how to perform a crossover for the mid-density (MD) value. Assume the step at which the MD is read has been previously determined to be step 6. The previously established target value of the MD (for the old film) is 1.21. On the new film, the step at which the MD is read is determined to also be step 6. The optical density of step 6 for both films, which have been measured using a densitometer, are as follows:

Strip	Mid-density	
	"Old" film emulsion	"New" film emulsion
1	1.25	1.18
2	1.25	1.17
3	1.24	1.18
4	1.25	1.19
5	1.24	1.30
6	1.26	1.18
7	1.25	1.17
8	1.24	1.18
9	1.25	1.18
10	1.25	1.18
Average:	1.25	1.18

There are a number of interesting items in this data. First, the mid-density of the old control film is 0.04 higher than the operating level. This implies that the processor is not operating exactly at its "target" level (which is perfectly fine, as long as it is operating within the control limits, which it is). This also implies that the user will somehow need to adjust the "new" operating level to compensate for the current state of the processor. Another interesting item is evident in the "new" film data. Strip number 5 shows a density measurement of 1.30. This is significantly different from the remaining data for the new film. It is an outlier and is not used in the calculation of the average.

The next step is to calculate the difference between the average “old” film mid-density and the operating level. As previously mentioned, the mid-density of the “old” film is 0.04 greater than the operating level ($1.25 - 1.21 = 0.04$). To compensate for the current operating state of the processor, one should subtract 0.04 from the average mid-density of the “new” film, yielding 1.14 ($1.18 - 0.04 = 1.14$). The operating level for the mid-density of the “new” film is then 1.14.

4. Processing sensitometry strips

To achieve best results, always

- (a) feed less exposed end of strip into the processor first,
- (b) feed the film in on the same side of the processor,
- (c) feed the film in with the same orientation (e.g., emulsion side up),
- (d) use the same delay between the time the film is exposed to the sensitometer and the film is developed.

ACKNOWLEDGMENTS

One of the authors of the present document (S.W.) was the primary author of Ref. 5. Many of our figures have been adapted from that reference as has some of the information on performing QC tests using phantoms that are presently commercially available. We wish to thank fellow members of the AAPM Ultrasound task group for their constructive criticisms of this manuscript in its many stages of development. In particular, we would like to thank Jim Zagzebski, Carolyn Kimme-Smith, Tim Hall, Bill Clayman, Brian Fowlkes, Evan Boote, Al Goldstein, Mike Insana, and Hector Lopez for their comments and suggestions.

APPENDIX A: ABBREVIATED PERFORMANCE TEST INSTRUCTIONS ULTRASOUND QUALITY CONTROL

Perform quick scan tests (display monitor fidelity, depth of visualization, hard copy fidelity, distance accuracy, and image uniformity) and physical and mechanical inspection every three months for mobile systems and every six months for others. Use only the most frequently employed transducer for these tests. Once a year, perform a more thorough examination of the system including all of its transducers. In addition to the tests listed above, perform tests of anechoic object imaging, axial and lateral resolution, and dead zone. Test the machines at the end of service visits while the serviceman is still present or at least as soon as possible thereafter.

Most frequently performed tests:

(1) Physical and mechanical inspection:

- (a) Transducers: Check cables, housing, and transmitting surfaces for cracks, separations, and discolorations. Check mechanical real-time transducers for smooth vibration-free motion and for possible presence of air bubbles. Also check condition of connectors.
- (b) Power cord: Check for cracks, discoloration, and damage to cable and plug.

- (c) Controls: Check operation of switches and knobs, note burnt out bulbs.
- (d) Video monitor: Check for cleanliness and scratches and operation of controls.
- (e) Wheels and locks: Verify proper operation of wheels and locks.
- (f) Dust Filters: Check for cleanliness. Person responsible should clean or replace filters at regular intervals.
- (g) Scanner housing: Check for dents and other damage.

(2) Display monitor fidelity and hard copy fidelity part I. Procedure:

- (a) Verify that contrast and brightness knobs on display monitor are in baseline positions.
- (b) Display grayscale step-wedge pattern on TV monitor.
- (c) Note first and last steps that are visible as well as total number of steps that are visible. Compare with baseline values.
- (d) Examine text on display for blur.
- (e) Make a hard copy of the image.
- (f) Note first and last steps that are visible as well as total number of steps that are visible in hard copy. (Should equal baseline values.)
- (g) Measure ODs of four steps selected at baseline (e.g., lightest and darkest, and two in-between). Compare with baseline values.

(3) Image uniformity

Setup: Use baseline settings on data sheet if available. Use cardboard template for TGC settings if created during baseline studies.

Suggested settings:

- (a) Generate images using both single and multiple focal zones.
- (b) Adjust gain and TGC to baseline values (should produce moderate image brightness, uniform with depth). Use cardboard template to set TGC if employed at baseline.

Procedure:

- (a) Scan across phantom and freeze image while moving transducer.
- (b) Examine image for streaking.
- (c) If streaking is present, repeat scan at another phantom location to ensure streaking is not a result of poor coupling or phantom artifact. Also change focal zones or select fewer or more focal zones to determine if this has an effect on the streaking.
- (d) If above does not eliminate streaking, store and/or photograph image displaying streak. Note gain setting and output settings and gray level of streak. Using stored or photographed image as reference, adjust gain or output to bring signals adjacent to streak to original gray level of streak.

Record image nonuniformity = new gain or output setting – original setting.

(4) *Maximum depth of visualization and hard copy fidelity part II.*

Setup: Use baseline settings on data sheet if available. If not, adjust system output and gain, TGC, persistence and the focal zone so as to obtain a relatively uniformly bright image that displays background texture echoes to as great a depth as possible. Use cardboard template for TGC settings if template was created during baseline studies.

Suggested settings (may need to be adjusted for desired image uniformity):

- (a) Deepest focal zone.
- (b) Gain and output power at maximum.
- (c) TGC at full gain where signal begins to falloff and beyond.
- (d) Reject off or at minimum.
- (e) Field of view to value that permits maximum depth of visualization.

Note: Record all settings for future use.

Procedure:

- (a) Scan phantom and freeze image. (If possible, include gray bar along with image.)
- (b) Measure and record penetration, which is distance from top of scan window to the deepest spherical or cylindrical anechoic object of a particular size that is barely visible, or to the depth at which the background texture can barely be seen reliably.
- (c) Photograph the display and process the film, leaving the display frozen.
- (d) Measure penetration visible on film.
- (e) Verify that weakest echoes on the display are visible on the film.
- (f) Verify that the small gaps of nearly full brightness between very strong echoes are as visible on the film.
- (g) Check and record whether the *processor QC* has been performed and processor is functioning properly.

(5) *Distance accuracy*

Setup: Use the same scanner setup as in the depth of visualization test.

Procedure:

- (a) Scan phantom so vertical column of filament targets appears toward the center of the image and a set of horizontal targets is also visible. Apply transducer to scanning membrane with little pressure. Freeze image, include depth markers and photograph.
- (b) Vertical distance accuracy: Use calipers to measure distance between most widely separated filament targets in vertical column displayed in image. (Place caliper cursors at tops of echoes.) Record measured distance on QC form.
- (c) Use normal method to measure corresponding distance on photographed image. Again record measured distance.
- (d) Horizontal distance accuracy: Repeat above analysis in displayed and photographed images for horizontal row

of filament targets. (Place caliper cursors above or below centers of echoes.)

LESS FREQUENTLY PERFORMED TESTS:

(6) *Anechoic object imaging*

Setup: Use baseline settings on data sheet if available.

Suggested Settings

- (a) Multiple focal zones set at depths of multiple size cyst-like objects in phantom (e.g., 3, 7, 11 cm) (or set single focus at these depths).
- (b) Adjust gain, power, and TGC to display maximum number of anechoic objects.

Note: Record settings for future use.

Procedure:

- (a) Scan phantom. Record smallest anechoic object that can be visualized at specific depths (e.g., at 3, 7, and 11 cm).
- (b) For anechoic object just larger than smallest perceived, measure and record height and width, and height/width ratio. Also record cyst image quality (*c*=clear, *f*=filled in, *J*=jagged edge, *N*=no enhancement).
- (c) For one or more of the larger anechoic objects with fill-in, reduce the gain until the fill-in disappears. Record the new gain value(s).

(7) *Axial Resolution*

Setup: Use same settings as in anechoic object perception test. Decrease gain so background texture is barely visible.

Procedure:

- (a) Scan phantom, zooming maximum amount at each axial resolution target group. (See Fig. 6.)
- (b) Record axial resolution=smallest separation between targets that can be perceived at each depth or FWHM and/or FWTM of axial profile through a single target at a specific depth.

(8) *Lateral resolution or response width*

Setup: Use same setup as in axial resolution test.

Procedure:

- (a) Scan phantom in region containing vertical column of filaments.
- (b) Reduce FOV to just view either a single filament in the focal region or the set of lateral resolution filaments. If possible, zoom in on the filament(s).
- (c) Freeze the image.
- (d) Use calipers to measure the lateral resolution or response width=width of the filament in the focal region. (See Fig. 7.) Record this value. Alternatively, have system generate a lateral profile through a target of interest, and compute the FWHM and/or FWTM of that profile.
- (e) Repeat for different focal regions.

(9) *Ring down or dead zone*

Setup: Use same setup as in axial resolution test. (Use the shortest focal zone.)

Procedure:

- (a) Scan phantom in region containing dead zone test filaments. (See Fig. 8.)
- (b) Freeze image and determine closest filament that can be imaged. Record dead zone=depth of this filament.

APPENDIX B: QUALITY CONTROL FORMS

Following are some examples of proposed QC Test Forms. These are models which should be modified to meet the user's particular needs. The forms should not be construed to be finalized. They will evolve as the tests themselves change with time (see diagrams 1-8).

1) Physical and Mechanical Inspection

a) Transducers: Check cables, housing, face & connectors for cracks, separations, air bubbles & discoloration.

Date																				
OK																				
Problem																				

b) Power cord: Check for cracks, discoloration & damage to cable & plug.

OK																				
Problem																				

c) Controls: Check operation of switches & knobs, note any burnt out bulbs.

OK																				
Problem																				

d) Video monitor: Check for focus, cleanliness & scratches, & operation of controls

OK																				
Problem																				

e) Wheels and Wheel Locks: Check that wheels rotate freely and are secure. Make sure locks work.

OK																				
Problem																				

f) Dust Filters: Check for cleanliness. Clean or replace if part of one's responsibility.

OK																				
Problem																				

Date:	Event																			

2) Hardcopy and Display Monitor Fidelity

Room: _____ Tested by: _____
 Ultrasound System: _____ Test Period: _____
 Transducer: _____ Phantom: _____

Baseline Settings:	
Power _____	Focal Zone: _____
Gain _____	System Default: _____
TGC: _____	Dynamic Range: _____
FOV: _____	Pre-Processing: _____
Reject: _____	Post-Processing: _____

TV Monitor Knob Positions: Contrast: $\begin{matrix} N \\ \bigcirc \\ S \end{matrix}$ E Brightness: $\begin{matrix} N \\ \bigcirc \\ S \end{matrix}$ E

Number of Gray Bars Visible on Display Monitor and Hardcopy:

Date																				
Lowest Gray Bar Displayed																				
Highest Gray Bar Displayed																				
Tot. No. of Bars																				
Monitor Focus Adequate (Y/N)																				

Weakest echoes & gray bars on display also visible on hardcopy? (Circle Y or N)

Y	Y	Y	Y	Y	Y	Y	Y	Y	Y	Y	Y	Y	Y	Y	Y	Y	Y	Y	Y	Y
N	N	N	N	N	N	N	N	N	N	N	N	N	N	N	N	N	N	N	N	N

Strongest echoes & gray bars on display also visible on hardcopy? (Circle Y or N)

Y	Y	Y	Y	Y	Y	Y	Y	Y	Y	Y	Y	Y	Y	Y	Y	Y	Y	Y	Y	Y
N	N	N	N	N	N	N	N	N	N	N	N	N	N	N	N	N	N	N	N	N

OD's of 4 Selected Gray Levels in Hardcopy Image of Gray-scale Test Pattern

OD 1																				
OD 2																				
OD 3																				
OD 4																				

Date of last processor QC tests:

Date:																				
-------	--	--	--	--	--	--	--	--	--	--	--	--	--	--	--	--	--	--	--	--

3) Image Uniformity

Room: _____ Tested by: _____
 Ultrasound System: _____ Test Period: _____
 Transducer: _____ Phantom: _____

Baseline Settings:	
Power _____	Focal Zone: _____
Gain _____	System Default: _____
TGC: _____	Dynamic Range: _____
FOV: _____	Pre-Processing: _____
Reject: _____	Post-Processing: _____

TV Monitor Knob Positions: Contrast: $\begin{matrix} N \\ \bigcirc \\ S \end{matrix}$ E Brightness: $\begin{matrix} N \\ \bigcirc \\ S \end{matrix}$ E

Baseline values: vertical _____ dB; horizontal _____ dB
 Action Values Nonuniformity 4 dB or, any consistent measurable change from baseline

Date:																				
vertical banding	none																			
	noticeable																			
	serious																			
Any above baseline?	dB =																			
horizontal banding	none																			
	noticeable																			
	serious																			
Any above baseline?	dB =																			
misc. artifacts	none																			
	noticeable																			
	serious																			
	dB =																			

Date:	Event																			

4) Depth of Visualization

Baseline Value: _____ cm
 Action Values (Baseline \pm 1 cm) = _____ cm and _____ cm.

Date																				
On Display																				
On Hardcopy																				

Date:	Event																			

5) Vertical and Horizontal Distance Accuracy

Room: _____ Tested by: _____
 Ultrasound System: _____ Test Period: _____
 Transducer: _____ Phantom: _____

Baseline Settings:	
Power _____	Focal Zone: _____
Gain _____	System Default: _____
TGC: _____	Dynamic Range: _____
FOV: _____	Pre-Processing: _____
Reject: _____	Post-Processing: _____

Vertical Baseline Value: _____ cm (identity of filaments for measurement: _____ cm & _____ cm)
 Action Values (Baseline \pm 1.5 mm or 1.5%) = _____ cm and _____ cm.

Horizontal Baseline Value: _____ cm (identity of filaments for measurement: _____ cm & _____ cm)
 Action Values (Baseline \pm 2 mm or 2%) = _____ cm and _____ cm.

Date																				
------	--	--	--	--	--	--	--	--	--	--	--	--	--	--	--	--	--	--	--	--

Vertical Distance Determined From:

Ult. Scanner																				
Hardcopy																				

Horizontal Distance Determined From:

Ult. Scanner																				
Hardcopy																				

6) Anechoic Object Perception

Room: _____
 Ultrasound System: _____ Test Period: _____
 Transducer: _____ Phantom: _____
 Tested by: _____

Baseline Settings:		Focal Zone: _____
Power _____	Gain _____	System Default: _____
TGC: _____	Dynamic Range: _____	
FOV: _____	Pre-Processing: _____	
Reject: _____	Post-Processing: _____	

Depth	Smallest Anechoic Object that can be Visualized:			
3 cm				
7 cm				
11 cm				
Date:				

Ratio of height (h) to width (w) & Image Quality for objects that are just larger than the smallest seen.

Depth 3 cm	Obj best seen:				
	height (h)				
	width (w)				
	h/w				
Image Quality:	clear				
	filled in				
	jagged				

Depth 7 cm	Obj best seen:				
	height (h)				
	width (w)				
	h/w				
Image Quality:	clear				
	filled in				
	jagged				

Depth 11 cm	Obj best seen:				
	height (h)				
	width (w)				
	h/w				
Image Quality:	clear				
	filled in				
	jagged				
Date:					

Depth	5 mm or _____ mm Anechoic Object Signal to Noise Ratio and/or Gain setting for zero fill-in			
3 cm				
7 cm				
11 cm				
Date:				

7) Axial Resolution

Room: _____ Test Period: _____
 Ultrasound System: _____ Phantom: _____
 Transducer: _____
 Tested by: _____

Baseline Settings:		Focal Zone: _____
Power _____	Gain _____	System Default: _____
TGC: _____	Dynamic Range: _____	
FOV: _____	Pre-Processing: _____	
Reject: _____	Post-Processing: _____	

Baseline Value(s): _____ mm (Depth of target group (s): _____ cm & _____ cm)
 Action Values: 1 mm, or 2 mm if Freq < 4 MHz.

Depth	Axial Resolution (Check appropriate box.)			
_____ cm	2 mm			
	1 mm			
	0.5 mm			
	0.25 mm			
Date:				

Depth	Axial Resolution (Check appropriate box.)			
_____ cm	2 mm			
	1 mm			
	0.5 mm			
	0.25 mm			
Date:				

Depth	Axial Resolution (Check appropriate box.)			
_____ cm	2 mm			
	1 mm			
	0.5 mm			
	0.25 mm			
Date:				

Date:	Event

8) Lateral Resolution

Room: _____ Test Period: _____
 Ultrasound System: _____ Phantom: _____
 Transducer: _____
 Tested by: _____

Baseline Settings:		Focal Zone: _____
Power _____	Gain _____	System Default: _____
TGC: _____	Dynamic Range: _____	
FOV: _____	Pre-Processing: _____	
Reject: _____	Post-Processing: _____	

Baseline Value(s): _____ mm @ _____ cm depth; _____ mm @ _____ cm depth; _____ mm @ _____ cm depth
 Action Values: > 2.5 x focal length / (freq in MHz x aperture diameter in mm) or change > 1 mm from baseline value

Depth of filament	Lateral Resolution (mm) (Check appropriate box.)			
_____ cm	_____ mm			
	_____ mm			
	_____ mm			
	_____ mm			
Date:				

Depth of filament	Lateral Resolution (mm) (Check appropriate box.)			
_____ cm	_____ mm			
	_____ mm			
	_____ mm			
	_____ mm			
Date:				

Depth of filament	Lateral Resolution (mm) (Check appropriate box.)			
_____ cm	_____ mm			
	_____ mm			
	_____ mm			
	_____ mm			
Date:				

Date:	Event

9) Ring Down or Dead Zone

Room: _____ Test Period: _____
 Ultrasound System: _____ Phantom: _____
 Transducer: _____
 Tested by: _____

Baseline Settings:		Focal Zone: _____
Power _____	Gain _____	System Default: _____
TGC: _____	Dynamic Range: _____	
FOV: _____	Pre-Processing: _____	
Reject: _____	Post-Processing: _____	

Baseline Value(s): _____ mm
 Action Value(s) = 7 mm for transducer center frequency (f) 3 MHz
 5 mm for 3 MHz < f < 7 MHz
 3 mm for f > 7 MHz

Value	Check Appropriate Box:			
10 mm				
7 mm				
5 mm				
4 mm				
3 mm				
2 mm				
1 mm				
Date:				

Date:	Event

APPENDIX C: EXAMPLES OF POSSIBLE PHANTOM DESIGNS

As stated previously, the authors are not advocating a particular phantom design. Below are two examples of phantoms that contain most of the elements needed to perform the

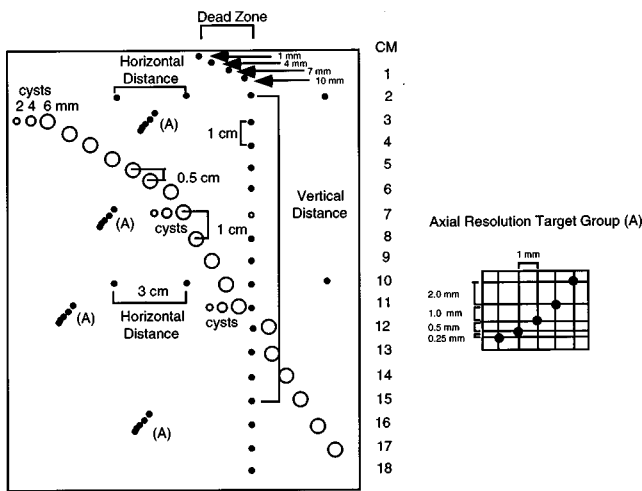

FIG. 10. Traditional TM phantom with additional cylindrical anechoic objects for easier interpretation of depth of visualization.

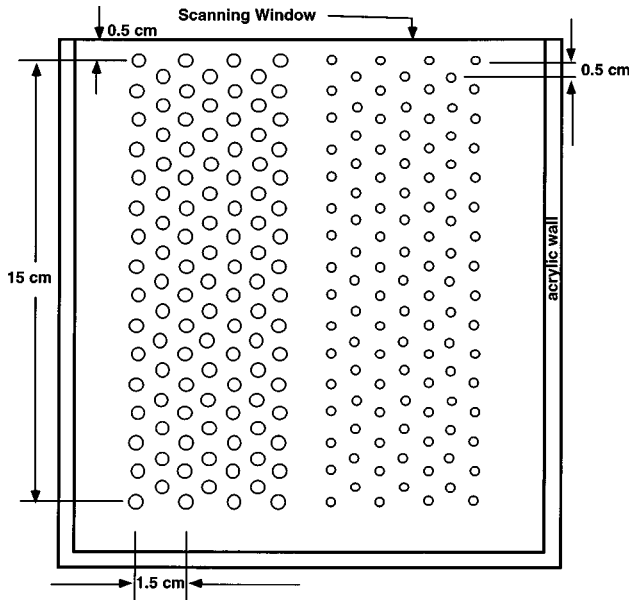

FIG. 11. Sketch of a phantom containing spherical lesions in regular arrays (Refs. 4 and 8). A group of lesions of one size (e.g., 4 mm in diameter) is shown on the left, and a second group of a different size (e.g., 3 mm in diameter) is shown on the right. The centers of all lesions are coplanar, and the echogenicity of all lesions is a fixed dB (e.g., 15 dB) below background. This phantom could be modified to include filaments so that it could be used for most QC tests.

QC tests described in this manual. The first design (Fig. 10) is similar to the traditional phantoms offered by several manufacturers with the addition of more anechoic cylinders for better interpretation of depth of visualization. This design includes axial resolution target groups that are not as effective in quantifying axial resolution as axial profiles of displayed echoes from single filaments. It is hoped that in the near future, most ultrasound manufacturers will incorporate profiling capabilities in their instruments including analysis of full width at half-maximum and full width at tenth-max both in the axial and transverse directions. The second phantom design (Fig. 11) employs regular arrays of spherical lesions. Proper scanning of the phantom is facilitated by the fact that the centers of the lesions are coplanar. User analysis of the images is speeded up by the fact that the lesions are in a known fixed pattern. This design is also advantageous for computer analysis of the images.

^{a)}Editor's Note: Readers of this Task Group Report are encouraged to also read the Letter to the Editor by Goldstein on p. 1547 in which he criticizes parts of the report and the response by Goodsitt, Carson, Hykes, and Kofler on p. 1552.

^{b)}Author to whom all correspondence should be addressed at Department of Radiology, University of Michigan Hospitals, 1500 East Medical Center Drive, Ann Arbor, Michigan 48109-0030. Electronic mail: goodsitt@umich.edu

^{c)}Present address: Philips Ultrasound, Santa Ana, CA 92704.

¹J. E. Gray, N. T. Winkler, J. Stears, and E. D. Frank, *Quality Control in Diagnostic Imaging* (Aspen, Rockville, MD, 1983).

²NCRP Report No. 99, "Quality assurance for diagnostic imaging. National Council on Radiation Protection and Measurements," National Council on Radiation Protection, Bethesda, MD, 1988.

³AIUM, *Methods For Measuring Performance Of Pulse-Echo Ultrasound Equipment-Part II: Digital Methods (Stage 1)*, edited by H. Lopez et al. (American Institute of Ultrasound In Medicine, Laurel, MD, 1995).

⁴AIUM, *Quality Assurance Manual for Gray Scale Ultrasound Scanners (Stage 2)*, edited by E. Madsen et al. (American Institute of Ultrasound In Medicine, Laurel, MD, 1995).

⁵*The Ultrasound QA Cookbook* (Gammex RMI, Middleton, WI, 1994).

⁶*Mammography Quality Control Manual*, revised edition (American College of Radiology, Reston, VA, 1994).

⁷J. M. Kofler, J. E. Gray, J. T. Fuelberth, and J. P. Taubel, "Quantitative evaluation of low-cost frame-grabber boards for personal computers," *J. Digital Imaging* **8**, 191-197 (1995).

⁸J. J. Rownd, E. L. Madsen, J. A. Zagzebski, G. R. Frank, and F. Dong, "Phantoms and automated system for testing the resolution of ultrasound scanners," *Ultrasound Med. Biol.* **23**, 245-260 (1997).

⁹J. E. Gray, K. G. Lisk, D. H. Haddick, J. H. Harshbarger, A. Oosterhof, and R. Schwencker, "Test pattern for video displays and hard-copy cameras," *Radiology* **154**, 519-527 (1985).